



**Model AF-PM
Pedestal Fan**

A high performance portable pedestal fan with a superior design. The model AF-PM delivers substantially more air than other type pedestal or box fans.

Features

- Heavy duty wheeled base for easy maneuverability.
- Direct driven for minimal maintenance.
- High performance zinc-alum propeller.
- Attractive deep spun 14 gauge steel housing.
- Safety guards on both the inlet and exhaust side of fan. 1/2" mesh galvanized steel screen.
- Motor mounting bracket designed to fit most standard off the shelf motors.
- Power cord furnished on single phase units only.
- Fan housing coated with a thermally fused powered polyurethane black finish.
- 2 year warranty.

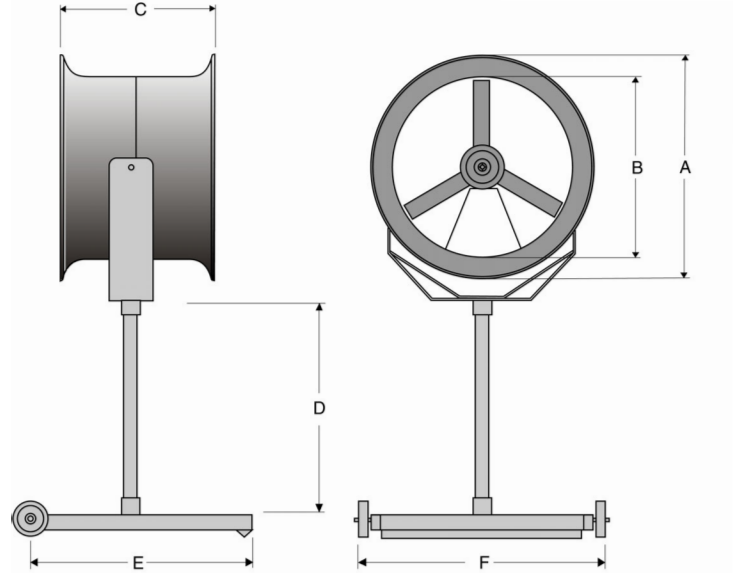

ROMLA VENTILATOR CO.
9668 Heinrich Hertz Drive • Unit D
San Diego, California 92154
Ph (619) 946-1224 Fax (619) 946-1227

AF- PM DIMENSIONS AND WEIGHTS							
SIZE	A	B	C	D	E	F	SHIP WT
14	14-1/2	20	16	28-1/2	30	29	76
18	19	24	16	28-1/2	30	29	98
22	22-1/4	29	16	28-1/2	30	29	85
30	30-1/2	37	22	28-1/2	30	29	155

SPECIFICATIONS

QTY	MODEL NO.	TAG	AREA OF COVERAGE (SQ FT)	DISTANCE AIR THROW (FT)	CFM	RPM	HP	VOLTS	PH	HZ	TYPE

<p>PROJECT: LOCATION: SUBMITTED BY: DATE:</p>	<p>CONTRACTOR: ENGINEER: APPROVED BY: DATE:</p>
--	--